

Urban sprawl processes: using QuAG to sensitize stakeholders for the interdependencies between actors

Diana Meyer-Veden and Klaus Eisenack

Potsdam Institute for Climate Impact Research

The paper introduces a role-play to enhance the understanding of city regions' development by a social simulation of the allocation of actors between urban and suburban areas. Based on a qualitative computer model with similar rules and elements, in the game the interactions between the actors are solely performed by the participants. They represent the actors being involved in the city development process, divided between moving (e.g. residents, industry, retail) and non-moving actors (planners and politicians). Development in space depends on the attractiveness of the area and the preferences of the actors. In turn, the attractiveness of an area alters with changes in the location of actors and is manipulated by planners. The role-play was developed to sensitize professional planners and planning students towards the interdependencies of actors, their contribution to a region's attractiveness, and to make the computer model more tangible.

Keywords: mathematical model; migration; neighborhood attractiveness; qualitative differential equation; stakeholder; sustainable development; urban planning.

Introduction

Urban sprawl is a common process in many western city regions. Starting in the US in the 1920's, European cities experience middle-class urban sprawl since about the 1960's. Urban sprawl is understood as a spreading of urban settlements over the original fringes of urban areas into the formerly untouched countryside and along major transport routes, featuring low-density development, a decrease in social mixing and mostly a mono-functional land use (see e.g. Galster, 2001; Squires, 2002; Cieslewicz, 2002; Jargowsky, 2002). The increase in living standards and spare time in most Western societies but also modern transportation technology enable private and economic entities to re-evaluate spatial characteristics and resulted in sprawl most often. In turn urban sprawl has negative and positive consequences on these characteristics of a place.

To satisfy the requirements of a modern welfare society, the consequences of urban sprawl (especially the negative ones) need to be balanced in order to meet the preferences of private, economic and public actors. For example, in the last two decades and especially since the Rio Earth Summit (1992), an urgent need to implement sustainable development has been pronounced. The necessity to bring different interests (as e.g. economic, ecological and social) under an overarching and guiding umbrella is crucial. Here, adequate institutional

arrangements for planning are an important pre-requisite. Major obstacles result from the discrepancy between positive consequences for private entities willing to locate in suburban regions because of higher perceived living quality (met by different characteristics, e.g. more green space, more living area, cheaper housing prices, etc. compared to the inner cities) and the negative consequences for the community as a whole (e.g. environmental deterioration and fragmentation, social segregation, potential inner city deterioration and the loss of taxes if the development areas are lying outside of the city border etc.). The causes and consequences of sprawl are often located on different spatial and institutional scales, which makes sprawl difficult to handle.

The negative effects of wide-spread middle-class urban sprawl have not been redressed in about 80 years starting from their first observation in the US and 40 years in Europe respectively. It leaves the impression that the urban sprawl process is not fully understood to the present date. Scientific analyses of land-use planning need to identify functional relationships between a (planning) action and its result, presupposing the ability to influence the systems' parameters, but experience with sprawl in the past indicates only limited regulation abilities of planning authorities. However, we assume that some important, even crucial aspects have not received adequate attention: the relationships between the actors. People often do not decide from a rational and sound reasoning, but follow opinions that depend on other actor's choices. Therefore the social composition of neighborhoods is an important issue for residential migration and network building. Also for the locational considerations of firms synergy effects are of important (Gordon & McCann, 2000). Thus, actors are contributing to the attractivity of a region, they are a feature of an area and therefore need to be included in attractivity evaluations and preference estimations (Allen, 1997; Wiest, 2001; Herfert, 2003).

Serious concerns have been expressed for the use of computer simulations for urban planning. Fostered by the strong belief in deregulation after the 1970s but also due to various epistemological and methodological objections they have hardly been used as instruments of policy analysis and urban development prediction. Concerns are related to the use of large-scale quantitative models often claimed being of general purpose (Cecchini & Rizzi, 2001) and to the application of models for land-use changes (Couclelis, 2005). Large models tend to become a black box, making them an unsuitable tool for learning. On the other hand, the complexity and contingency of social processes makes deterministic predictions impossible. Further problems in modeling coupled socio-economic and bio-physical systems are difficulties in quantifying qualitative characteristics, heterogeneous knowledge from different scientific disciplines and uncertainties that cannot be expressed by probabilities (cf. Eisenack, 2006).

We assume that most of these drawbacks are related to a narrowed view on available formal methods and their use. A broad set of mathematical and computational methods that deal with uncertainties, non-quantitative data or exploration instead of prediction is available (e.g. viability theory (Aubin, 1991), field anomaly relaxation (Rhyne, 1995), cellular automata (e.g. Tobler, 1979), fuzzy sets (Zadeh, 1965), neural networks (e.g. Zell, 1994) and others). The game we present in this paper is based on a computer model of urban development formulated by means of qualitative differential equations (QDEs, Kuipers, 1994). Called QuAM-Model (Qualitative Attractivity-Migration Model), it is made to reproduce the observed, past and present development of selected urban areas in a non-deterministic way (for examples see Lüdeke & Meyer-Veden, 2006; Meyer-Veden & Lüdeke, 2006). We then demonstrate an alternative use of the model by transforming its underlying assumptions to a pure social simulation that does not involve any computations. The resulting role-play, call QuAG

(Qualitative Attractivity-migration Game) is designed to initiate learning processes instead of presenting a black box.

Both the model and the game were designed in a EU funded research project called Urbs Pandens (see <http://www.pik-potsdam.de/urbs>), which was performed in close collaboration with stakeholders from European local and regional planning boards. The model shows high applicability and usefulness for understanding urban sprawl as viewed at in the way we described above (Lüdeke et al., 2003; Lüdeke et al., 2004). The crucial model assumptions of interdependent actors and attractivity dimensions were incorporated into QuAG. Since non-scientists, especially responsible persons from politics and planning, are the main target group for using the model, overcoming reservations about models seemed necessary to make the kind of “thinking” that lies behind the computer model more tangible to its users while disseminating its application. The structure of the model constituted of actor classes and their interdependencies offers a well-suited base for the transfer of the main model assumptions to a game. The importance of actors is easy to emphasize within a role-play, and the people are directly affected by the interdependent influence on a region’s attractivity in their role.

By that, we introduce an urban gaming simulation (UGS) model (cf. Coppard & Goodman, 1979), but use it to initiate learning processes instead of computing the best control options. In this spirit, UGS “are mainly urban training tools for planners and politicians, learning tools for students, and research tools for scientists. Like all gaming simulation techniques, UGS are tools for simulating the effects of decisions made by people ...” (Cecchini & Rizzi, 2001). They have proved to be excellent training tools and are therefore suitable and applicable to our purpose. Participants are faced with the consequences of their decisions, they are inside of the simulation (Torres & Macedo, 2000). Role playing games seem extremely helpful in decision processes where the circumstances to decide and the actual decision are taken by different entities. It places the players in a situation of a community for which they are responsible. Furthermore, simulation games have ice-breaking capacity and open up dynamic participation. They are known to lessen resistance to accept novel ideas and stimulate interest in the new issue by supporting group discussion (Petranek, 1994).

Whether this game helps to improve understanding of urban sprawl and whether planners regard such a tool as useful and adapt to new perspectives are the central questions addressed in the paper. We also investigate the relation of computer model, game and reality. The presentation is organized as follows. First, we introduce the QuAM-Model and its theoretical base. We then present QuAG, the structure of the game, the roles of the players, and the sequence of play. Experiences with the game and a comprehensive debriefing section follow. We finish with conclusions.

The QUALitative Attractivity-Migration - Model (QuAM)

Urban sprawl is a social process related to actors moving in space. It has causes in and consequences on natural, economic and social characteristics of a region, which together form multiple feedback loops. Feedbacks not only relate to the moving private or economic entities but to all actors present in the region. While actors are motivated to move within an urban area due to spatial attractivities, the changing composition of actors, jointly with planning regulations, alters the attractivity of a place in a region. Taking this into account, a model that

describes the dynamics of migration of actor classes in relation to the described attractivities in an urban region is appropriate to understand an important part of the sprawl process.

We characterize classes of actors (different kinds of residents, retailers, etc.) as being qualitatively homogeneous in assessing the attractivity of different urban regions. This means that they do not have to have identical preferences, but can be aggregated in a sense that is made precise below. Actor classes migrate along attractivity gradients, moving from a region of lower to a region of higher attractivity. Thereby they reduce the population of their class in the region they leave and increase the population in the region they move to. This migration changes the attractivity of both regions for all actor classes and cause further changes in migration fluxes. The model deals with net migration of actor classes: some actors of the class may well move into the other direction, but the model describes the direction of the net fluxes under mean preference assumptions. The preferences are specified by dividing overall attractivity into sub-categories, subsequently called dimensions of attractivity. Usually, dimensions of attractivity differ between and are specific for each actor class. They comprise factors like standard of flats, land prices, specific infrastructure etc. (see Tab. 1).

A table describes the interdependencies between actors and attractivities of a region (specific to each actor class), containing rows for each dimension of attractivity for each actor class, and a column for each actor class. The influence of a certain actor class onto a dimension of attractivity of (another or the same) actor class is marked in the entry corresponding to this class and dimension. This preference and influence patterns are summarized as an aggregated attractivity matrix that is used as input to the formal mathematical model. It has a row and column for every actor class, with a sign as coefficient. This represents whether an increasing presence of actors of a class given in a column aggregately improves the attractivity dimensions relevant for the actors class given by the row. A zero means that the influence is considered as negligible in the model. In a different representation the matrix can also be formulated as a causal loop diagram (as used in the systems dynamics literature, Forrester, 1968; Sterman, 2000). As Richardson (1986) has noted, different ways to interpret such a matrix are possible. We adopt the notion that a positive influence means that a high population of the influencing actor class increases the *change rate* of the influenced class. This is different from relationships where a high population of one actor class directly results in a high population of another. Taking into account the indolence of moving decisions in the urban environment, the former interpretation is more appropriate. Tab. 1 and Tab. 2 displays an example that was developed for the Leipzig periphery, one of seven case studies in the Urbs Pandens project (see Lüdeke & Meyer-Veden, 2006, for further details).

Tab. 1: Example for the attractiveness dimensions of an actor class (ordered by importance for each actor) and how they are influenced by actor class population changes.

Attractivity dimensions of Actor P ₁ :	Influence on attractivity dimension by actor class...			
	P ₁	P ₂	P ₃	P ₄
1. standard of flats	0	0
2. price	0	-
3. phys. environ.	0	0
4. infrastructure	0	0
5. neighbourhood	0	+
Aggregated Effect
Attractivity dimensions of Actor P ₂ :	P ₁	P ₂	P ₃	P ₄
...
Attractivity dimensions of Actor P _x :	P ₁	P ₂	P ₃	P ₄
...

Tab. 2: Resulting example for an aggregated attractivity matrix for four actor classes. In the Leipzig case, P1 denotes middle class families, P2 upper class families, P3 industry and P4 retail and leisure parks.

Population →	P1	P2	P3	P4
Attractivity of				
P1	0	-	0	+
P2	0	+	0	0
P3	0	0	+	0
P4	0	0	+	0

Qualitative differential equations only need the sign information contained in the attractivity matrix to perform a qualitative simulation. A quantitative assessment is not necessary. The mathematical theory behind this method was first introduced by Kuipers (1994). The solving and evaluation algorithm for the QuAM-Model are developed in Eisenack & Petschel-Held (2002), Lüdeke et al. (2003), Lüdeke & Meyer-Veden (2006) and Eisenack (2006). The main idea is to deduce as much consequences as possible about the dynamic behavior of the system if only the direction (A influences B) and the kind (A dampens or reinforces B) of the interactions between the actor classes is known. This is possible by – symmetrically – only considering the directions of change in the dynamics of model parameters (“trends”). The

algorithm computes the conditions under which trends of population (distinguished by actor classes) can reverse if an attractivity matrix is prescribed. Formally, this amounts in simultaneously solving an infinite ensemble of ordinary differential equations that share only common monotonicity properties. The result is a finite abstraction of *all* solutions of the ensemble (see Kuipers 1994; Eisenack 2006 for mathematical details). It contains all logically possible development paths, described as sequence of trends of the actor class population. Due to the general nature of the qualitative model, usually not a unique development path starting from given initial conditions exists. Of course, many development paths we can think of are not compatible with the attractivity assumptions. These are sorted out by the algorithm, such that all consistent potential futures remain, giving a result similar to a scenario analysis. Instead of making crisp predictions – which is hardly possible in the domain of urban dynamics – the method provides a mathematically justified exploration of multiple qualitative development paths that can serve as an input for subsequent communication and discourse processes.

The resulting set of possible trend sequences is described by a graph that contains all consistent trends combinations (so-called qualitative states) as nodes and possible trend changes as edges (arrows; see Fig. 3 for an example). Numbers are not needed. The step from the qualitative model (the qualitative assumptions about the interactions of the actor classes) to the resulting qualitative scenarios (the time development of the actor class populations) is purely deductive (without any additional normative input). Therefore implausible or even wrong (in case of hint-casting) scenarios mean always that the qualitative assumptions (relations between the actors) have to be reconsidered. Thus, the qualitative modeling procedure as applied here is a tool for generating a consistent system of plausible assumptions about interactions and qualitative scenarios for urban sprawl. The mathematical model is dynamic, but a structural change in interactions has to be assessed with a new model run nonetheless.

This approach allows for considering interactions that are not quantifiable. This general notion of influence of one parameter onto another has shown to be highly valuable in social modeling where quantitative relationships between the parameters are difficult to set. Furthermore, defining adequate parameters, for example living quality, aesthetical value of landscape etc., depending on the individual's perspective, are difficult to operationalize. Instead of measuring the exact value and change rate of parameters may be difficult, only the direction of influence between the variables needs to be clear. Defining parameters is easier when actor classes can specify their own, actor-dependent attractivity dimensions. For these reasons, qualitative modeling is increasingly used in sustainability science (e.g. Petschel-Held & Lüdeke 2001; Bredeweg & Salles 2003; Eisenack et al. 2006; Sietz et al. 2006).

In the analysis of the Urbs Pandens project it turned out that so called persistent trend combinations appear in many cases. This refers to situations where a trend cannot reverse at a later time any more. If all trends are persistent, the urban system has reached a kind of dynamic equilibrium, which can only be left if the fundamental attractivity structure is altered. The model output produces different scenarios about the future development of the urban region. By judging them for example in the light of sustainable development, policy recommendations and planning assistance can be given.

Figure 1: Valid trend successions according to the Leipzig attractivity matrix (see Tab. 2). Each column of the ellipses (qualitative states) symbolizes an actor class, with actor class 1 to actor class 4 from the left to the right column. An upward arrow stands for increasing populations, a downward trend for decreasing populations and a rhombus for the possibility of either direction (increasing or decreasing is possible and not clearly to evaluate). The region develops from one ellipse to the next indicating arrows from the left to the right hand side of the figure. The scenario character becomes visible where two arrows point to two successor states that can possibly both be reached. This is a very simple example. In intertwined cases the scenarios can follow totally different paths with different end-state s.

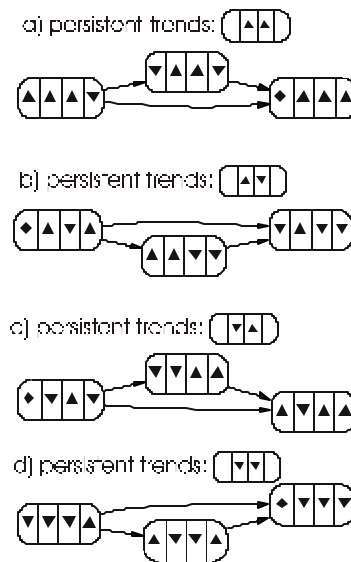

The Qualitative Attractivity-migration Game (QuAG)

The newly introduced assumption of inter-depending actor classes influencing the attractivity of a location along with the general reserves of stakeholders (as e.g. non-scientists from politics and planning) about using mathematical models (Couclelis, 2005) motivates the translation of the model into a role-play. In QuAG every player represents an actor class that moves in a virtual space by attractivity considerations. The players perform a social simulation, constituting the variables of the model. To increase participation and to extend the above objectives of the game, the real decision-making context of the planners who participate in the game is addressed by additionally introducing the roles of planners who can intervene into the game dynamics.

This is an important difference to the QuAM-Model, where the interactions (the aggregated attractivity matrix) are constant throughout a simulation run. Therefore, the model should only produce the same results as the game if there are no planning interventions (or if they are weak enough so that the preferences of the players remain roughly invariant during the session). However, the game is closer to reality since the actors in the game can adjust their preferences to a changing situation. The game is more dynamic as the model and has the potential to reproduce dynamics more appropriately. This can also be interpreted as if a single

QuAG session strings multiple QuAM model runs together. It was our initial hypothesis that this difference does not reduce the learning effect of the game, since it focuses mainly on conceptual learning (framing the problem in terms of dynamic attractivity patterns). We expect that the dynamics brought about by the model resemble the game dynamics if only the times between strong disruptions of attractivities during the session are considered.

Game setup and roles of the players

QuAG simulates the movement of actors in a hypothetical urban-suburban environment according to the attractivity of the regions, which can be influenced by urban and regional planning boards. Two types of players are introduced: moving and non-moving actors. While non-moving actors represent urban and regional planners who try to shape the urban environment intentionally, the moving actors represent residents, industry and retail that are moving along attractivity gradients between sub-regions (urban or suburban area) of highest attractivity.

During the game, the attractivity changes according to the subjective evaluation of moving actors when their attractivity dimensions change. This can result from a change in the composition of actors in the sub-regions or “neighborhoods” of moving actors (endogenous), a change of preferences (internally), or from the interventions of the non-moving actors (externally). The latter are made by the planners using action tokens that represent investments as e.g. the building of new infrastructure, the amelioration of environmental parameters etc. By that the non-moving actors can influence the development in the regions by complying with the attractivity dimensions of the moving actors. In turn, the attractivity changes alter the composition and population of the moving actors. The players are invited to assess the attractivity of their location in terms of attractivity dimensions related to other actors and planning decisions.

The whole region Regio (e.g. a class room) is divided into two sub-regions adjacent to each other, the urban zone Urbia and the suburban zone Suburbia, each represented by a row of chairs (see Fig. 2). The number of chairs on each side equals the total number of moving actors in the game, i.e. if players take their initial seats there also remains one empty chair per person. Additionally, three chairs on the gable-end are reserved for the non-moving actors, the planning authority of Urbia, Suburbia and Regio. The planners of Urbia and Suburbia can only play action tokens in their respective area (i.e. row of chairs), while the regional planner is free to allocate her action tokens between both areas. The regional planner can act integratively and comprehensively, equalizing or non-equalizing. The game is most efficient with a number of 15 to 19 players, of which three persons represent the planning boards of the three administrative levels.

Figure 2: Exemplary spatial arrangement of actors in the QuAM-Game.

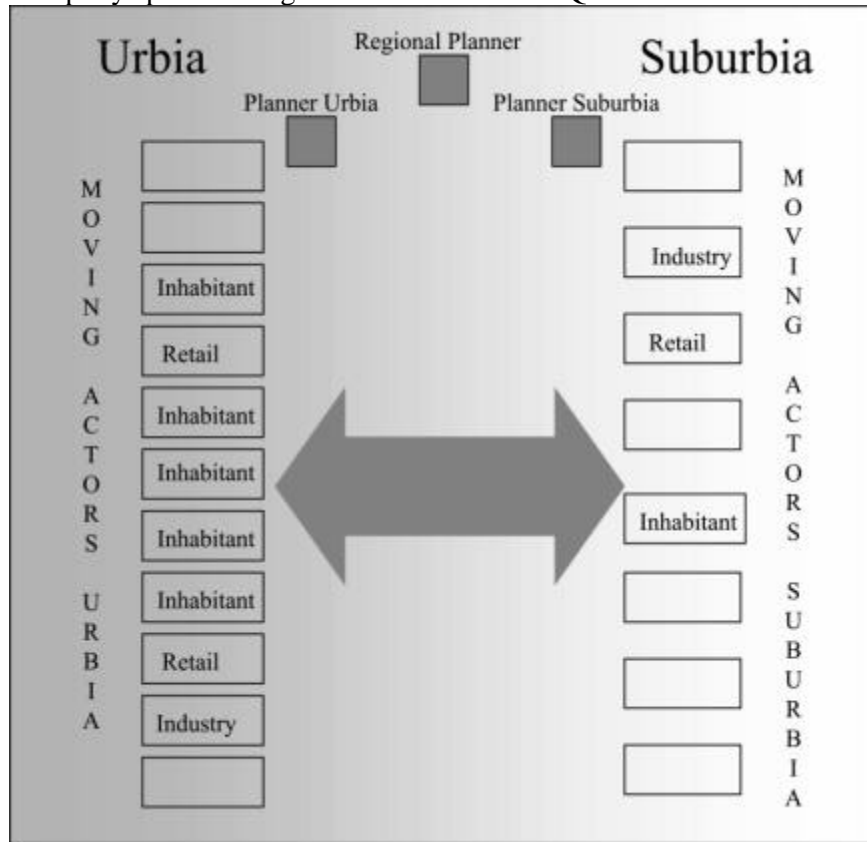

For each player only the *type* of role she takes is prescribed. The moving actors form a typical sample of actors building up a real city and therefore consist of industrial, retailing or residential entities. There should be approximately the double number of residents compared to actors from industry and retail. Within her type, each player is free to invent a concrete role and has to choose a name. A resident player can represent, e.g. a family, an old married couple or a single student; retail players can chose small shops, bars etc., while industry players represent larger firms. Not prescribing the roles in detail makes it more difficult to control the initial conditions of the game, but increases identification with the roles, therefore deepening the interest in the learning experience. Also, a representative, well-known name for a role (e.g. of important companies most player know) increases the identification with the role and gives an idea about the actors to other players. It makes the game very lively and fun. The spatial allocation of the actors is also of importance before starting the game. To reflect a mid-European city we always decided for placing the majority of players in Urbia and one residential, one retail and one industrial player in Suburbia as starting position.

Playing sequence

After the roles are distributed and the actors are located in the sub-regions the game starts. In the first phase every planner introduces her region. They evaluate the amenities, advantages and possible disadvantages of living in Urbia, Suburbia and Regio, respectively. They also

give a development goal for their sub-region that enables the moving actors to act upon. This goal is presented informally and is freely chosen by the player. Afterwards the moving actors introduce their roles to the plenary by announcing their name, their attributes and a short evaluation of the attractiveness of the sub-region they are initially located in. All moving actors are encouraged to elaborate on their respective attractiveness dimensions in terms of neighborhoods and general living conditions (“I like it to be here, because...”).

The second phase gives the opportunity of communication between planners and moving actors. An open discussion takes place representing the disclosure time of planning measures. This takes not place seated: all players are free to move in the room, form discussion groups, talk bilaterally, go to the planners or just stand aside and watch. No formal rules are defined for this phase, so the moving actors can form alliances and try to convince planners, as public interest groups are trying in reality. Since the attractiveness dimensions of the moving actors are different, a commitment of planners towards one actor’s preferences will change the attractiveness for all actors of the region in the ongoing rounds. The time of this phase is limited to 10-20 minutes, it’s end being announced by the facilitator.

After the discussion, the planners of Regio, Urbia and Suburbia implement specific political or planning measures that change the attractiveness of the region. These measures are understood as investments for which the planners use the action tokens (two or one measure per round and planner are reasonable – planners are also allowed to refuse investment at all). The planners do not need to work together to achieve a common goal, but they can act in concert. The tokens are played by writing a key word for the action on a blank sheet, putting it before the row of chairs it influences, and explaining it to the other players. No particular actions are prescribed, so that the players can “invent” new actions. Typical tokens are public infrastructure (e.g. parks, traffic systems), regulations or investments to set incentives for specific moving actors. If tokens are too general or abstract (“I employ a measure that makes the air clean for the rest of the game”), the facilitator requires the planner to become more specific.

In the final phase the moving actors decide whether the new characteristics in the sub-region they sit in meet their requirements, or if they should move to the other sub-region. If the attractiveness evaluation of the sub-regions reveals a higher attractiveness for the other sub-region the actor will move. First, every player decides on her own if she wants to go or to stay, then all players who chose to leave stand up simultaneously and go to a free chair of the other region. The people who are willing to stay remain on their seats. This marks the end of round one. The physical characteristics of the areas have been ameliorated or impaired, the city’s composition of actors has probably changed due to migration, both has altered the overall attractiveness for the actor classes and a second round begins along the described sequence.

The length of the game is not preset and depends on how the development goals are set, whether they are reached, whether the dynamics comes to an end, staying in a kind of equilibrium – which corresponds to the persistent trends discussed above. With additional rounds the dynamics gets more emphatic as the players get more familiar with their roles and the sequence of the game.

Experiences with QuAG

The game is used in a one-day workshop setting with professional local and regional planners. This setting aims at finding alternative action against urban sprawl processes and the introduction and evaluation of computer modeling techniques as a possible support tool for

planners' decisions. Therefore the game finds its application right in the context of transferring a modeling approach and making it tangible to its users. In the following we describe the experiences with the game in an explorative way.

A game session typically lasts about one hour excluding introduction and debriefing. It is requested during the game that the players make their decisions transparent. At the beginning of the game, players indicate which other actor types they prefer or dislike in their neighborhood. This is used to derive an attractivity matrix as needed in the QuAM-Model approach. After each round, every player is asked to explain why she has moved or not. These explanations are formulated in terms of their relation to other actors in the game. They are recorded by an assistant of the facilitator together with a visualization of the movements of actors. Debriefing takes place in two phases. The first phase starts directly after the game, while the second phase is part of the overall feedback at the end of the workshop.

The game session is observed by the facilitator and her assistants (who also record the game turn). Notes and photographs were taken, and the records of the game turns also provide data. The observations are organized with respect to (1) the social behavior of the participants, (2) the work of the facilitator and (3) the formal game dynamics.

The social behavior is relatively diverse. It emerged from the notes and pictures that the players participated in different styles, e.g. in the discussion rounds. Some were very enthusiastic and formed small discussion groups – partially to co-ordinate moving actors, partially they lobbied the planners of Urbia and Suburbia. They did not stick to their seats and moved freely in space. Other players behaved more cautious in the beginning, being reluctant in communicating with other players and making their decisions on their own. Some of these players began to socialize in later game rounds. The planners in the game do not have the chance to take a more silent role. Contrary, it is observed that these players are overloaded with requests from moving actors in the discussion round, such that they sometimes express being stressed by this situation. Visual expressions of this situation are small crowds of moving actors standing around a planner. Finally, some players seem skeptical about the game at all, resulting in limited participation. It was a general observation that new communication patterns evolve in the group of the workshop participants and that some people have the chance to meet who did not had the opportunity before. This is in accordance with observations from many other games (cf. Gosen & Washbush ,2004).

Recording the game dynamics is easy for the facilitator in most respects. Moving actors become visible by changed seats, and planning measures by action tokens. However, in every round it is necessary to remind the players to express their reasons for moving decisions in terms of attractivity arguments. Players tend to formulate these arguments referring to concrete moving actors in the game and not to actor types. However, as each player is member of a type, this can easily be translated into the actor type approach of the QuAM-Model. The records make it obvious that the attractivity matrix does not remain invariant during the game (as hypothesized by the underlying modeling approach), and it is quite difficult to keep track of these changes. One possibility could be to fill in the matrix after every round, but this was found as too time consuming. It is also expected that an introspection of the players does not always reveal the same preferences as they display through their decisions. If an attractivity matrix is to be determined, it is more practicable to derive it from the moving decisions and their underlying arguments. On the other hand, introducing the matrix is one important communication objective of the game, so that it was decided to start the game with a preliminary matrix discussed by the participants, but not to keep track of it during the game.

Although the game dynamics is different in every QuAG session, some typical patterns are observed. Even if players are personally motivated to avoid urban sprawl in the game, they often bring about the opposite effect in the first round: many moving actors leave Urbia. Various reasons may explain this effect. (i) There are initially more spare seats in Suburbia, making the impression of leaving an overcrowded city intuitively visible. (ii) A typical action token of non-moving actors to avoid sprawl is the introduction of an improved public transport system. This increases the attractiveness of Suburbia for many actors, since they obtain better access to facilities in Urbia even if they are not living there. (iii) In the first round players are more willing to move just to explore the possibilities of the game. Since initially more moving-actors are living in Urbia, more players are moving to Suburbia than in the other direction. At the current stage it is unclear whether the third effect (an artifact of the game) or the other effects (which are in line with the design objectives) dominate. In any case, this situation tends to produce a small “shock” for the players, leading to a more precautious behavior in later rounds (with the tendency to re-urbanize). Also, the overall dynamics becomes more static, meaning that in some rounds no players of some actor type move. This is in contrast to the QuAM-Model approach, which focuses on trends, disregarding constant conditions. A constant population of an actor type is, however, quite reasonable to occur in QuAG, since – compared to real cities – only a limited number of moving actors is simulated in the game. If players who do not move are asked to what degree they are satisfied with the current sub-region where they stay (which can range from *‘I really like being here’* to *‘I don’t like it here any more, but stay for a last round to give the opportunity for some change’*), the facilitator can get an impression of how the attractiveness changes even if no actor moves. The game speeds up again when the last round is announced, which must be classified as a bias since many actors are striving to maximize their final utility by getting as satisfied as possible. We thus recommend not to announce the end of the game.

Usually, the game is stopped after about four rounds due to time constraints or the impression of the facilitator that the game reaches a persistent state. To verify if it really is a persistent state, more rounds would need to be played, but with the risk to loose the tension and the attention of the players. However, players usually request more rounds, such that it may be interesting to extend the game if more time is available. One risk could be that some players start to behave more strategically if they have more experience with the game and with the other players – an effect that would be desirable for non-moving actors and for players who represent very powerful actors, but it could induce an artifact for example for private residents.

QuAG can be played with different numbers of action tokens from round to round. This is announced just before the planners decide about their planning measures, being an unpredictable intervention that makes the game lively. Such changes are justified by sudden reductions in community budgets, for example due to a drastic cut in governmental subsidies or an economic crisis. Our experience is that the influence of the planning measures onto the attractiveness of the region is very significant. The moving actors behave strongly in accordance to or against the planning measures. After the discussion round, the moving actors are very curious about which actions will be implemented and which actors’ preferences will be served by the planning measures. One can expect that planning measures taken in the real world could influence the attractiveness of an area similarly strong, a very important outcome for policy and planning design.

Debriefing

The debriefing process is based on two assumptions. First that the experience of participation has affected the participants in some way, and second that a processing of that experience is necessary to provide insight from the experience (Lederman, 1992). In addition to initializing learning processes, we also want to assess whether QuAG improves the understanding of the model approach. Moreover, we want to explore new variants of the game to increase its efficiency and to focus also on other issues of urban development. In this sense, debriefing of QuAG is meant to initialize a symmetric learning process for the players (which are experienced planners and thus experts) as well as the scientists who designed the game to incorporate a theoretic conception about urban development. To summarize, the objectives of debriefing QuAG are:

- Contribution to learning processes on urban sprawl and specific patterns thereof.
- Exploring new leverage points in urban planning.
- Initializing a learning process about the QuAM-Model approach and decrease skepticism against computer models.
- Assessing the model approach with experts from practice.
- Assessing the usability of the game in relation to the model and expert knowledge.

Generally, the debriefing process can be decomposed into the three phases: (i) introduction, (ii) self-reflection, and (iii) intensification of the analysis and generalization (cf. Lederman, 1992). In our case, this procedure is modified and extended due to the constraints of the workshop setup and due to the objectives of the study:

1. Directly after the game, the participants are invited to express shortly their impressions. Every participant describes her experience and feelings from the perspective of the role she had.
2. A group discussion is initialized, focusing on the patterns that emerged during the game. Comments are noted on a flipchart.
3. Participants are encouraged to draw general conclusions from the game. Also these comments were put on the flipchart.
4. Players are asked to comment on the realism of the game. They are also asked about their feelings regarding the attractiveness approach of QuAG.
5. At a general feedback session at the end of the workshop, participants can discuss the game again. After the workshop they have the opportunity to mail a feedback form to the workshop organizers. One open question on the form directly refers to the game (*“Wie eignet sich das Rollenspiel als Mittel der Schulung?” – “In which way is the role-play game an adequate method for training?”*).

Steps 3 and 4 are particularly important for the objectives of the game – step 3 for the learning processes of the participants and their evaluation, and step 4 to assess how reflecting on the relation of game, model and reality offers a useful new perspective. Furthermore, since formal models as well as games tend to introduce artifacts that have no meaning or are problematic in the real-world setting, reflection on the realism of the game is important to avoid misconceptions (cf. Greenblat & Duke 1981).

In the following we summarize the observations from the debriefing process of all steps, at first related to generalized conclusions of the participants, then to their opinion on the effect of the game, and finally to the realism of the game and the model approach.

Generally, many players come up with the conclusion that *‘the same mistakes are always repeated’* (“*Man sieht, dass man immer die gleichen Fehler macht*”) – meaning that although players have experience in planning practice, they produce unwanted behavior in the game. Such comments also indicate that this problem was not perceived as an artifact of the game, but as typical for real-world planning. However, other participants concluded that it would be more appropriate to play the game with politicians and not with planners, since the latter are already aware of the problems displayed by the game, while the former – setting constraints for planning decisions – should consider the causes of urban sprawl more thoroughly. It would be interesting to know how politicians would reflect on their relation to planners if they played QuAG.

The effect of the game is positively evaluated by most participants. A large part of the overall workshop feedback is devoted to the game session. Main comments are that the problem of urban sprawl becomes very vivid during the game (“*das Problem wird plastisch greifbar*”), and that the change of perspective (from planner to moving actor or from urban to rural planner) is very successful and illuminative (“*Der Perspektivwechsel war wichtig, gelungen und sehr erhellend*”). It is also stated that the game offers a good possibility to visualize the issues. This refers to the perception of empty and overcrowded areas of chairs in the game, as well as to the record of the game dynamics that was made visible during the game on a flip chart. Critical comments highlight that the transfer of game experiences to every-day decision-making is unclear. This stresses the importance of the debriefing process. However, the mere fact that the game draws the lion’s share of attention in a final feedback session underpins the depth of the game experience.

The reflection on realism and the relation between game, model and real-world situation is crucial for the further use of our approach. However, focusing debriefing on this issue proved to be difficult due to time constraints and since the game is made to provide only an introduction to the model. It can only be assessed whether the general approach is feasible. One artifact in “simulating” the moving actors in the game seems to be that some players admit that they act differently in the game compared with their real lives, in particular being less willing to move to Suburbia in the game. During the game they are biased by the problem awareness they already have due to their professional experience – otherwise they would most probably not participate at the workshop. If this is true, the suburbanization process would be less critical in the game than for real cities. On the other hand, even under these conditions the game dynamics tend to produce at least an initial migration to the suburbs, and interestingly (as mentioned above) some participants were surprised making certain mistakes in the game although they thought they should have known better. Most discussions regarding the realism of the game did not focus on artifacts but on potential extensions of the game. Such proposals typically reflect personal experiences or interests of the participants, but some of them seem worth to be included into future versions of QuAG. For example, it was suggested that the facilitator should prescribe the roles of the moving actors. In the original version, the roles are “invented” by the participants with the target of obtaining a higher degree of identification. On the other hand, prescribed roles can lead to a more “objective” behavior in the game, since preferences in the game are not so strongly linked to personal preferences – limiting the artifact discussed above. At the same time, this could increase the comparability of various game sessions since the initial conditions can be controlled to a higher degree. A similar suggestion is to prescribe a portfolio of management options for the local and regional

planners. This makes it, for example, easier for a rural planner to play an urban planner, since she may have only limited knowledge on the planning constraints from the other perspective. In this way, the learning effect of a changed perspective would potentially increase. Some of the proposals for extending the game clearly indicate processes that should probably be included in the formal QuAM-Model. For example, many planners stressed the importance of budget and time constraints, which are not explicitly included in the QuAM-Model. Such examples indicate an important and new way of using games jointly with formal models. In stakeholder workshops, scientists can validate and improve models without the need to explain the model, since the interaction is mediated by a game.

All together, it was stated that the actor and attractivity perspective promoted by the game and the model provides new insights for the participants. In this regard, the game was a successful vehicle to assess the relevance of the QuAM-Model, without the need to talk explicitly about formal models. Moreover, the realism of the game was confirmed by comments of the planners that non-expert players would definitely learn essential messages about urban sprawl from the game.

Conclusion

We have introduced a role-play to visualize the sprawl processes in an urban region. The game rationale is taken from a formal model developed for the same research focus. The main hypothesis underlying the computer model and the game is that actors in an urban-suburban environment are important determinants for the attractivity of a region. This is due to the presence of actors who directly determine the attractivity of the regions but also to the indirect influence on other attractivity dimensions. The chosen non-standard modeling technique is designed to take account of uncertainties and produces explorations instead of predictions. The game was developed for two objectives within professional training seminars for local and regional planners. First, planners should be sensitized for the importance of actors and their relation to attractivity in urban sprawl processes. Second, reservations against formal models to support planning purposes should be overcome. It was thus initially meant to provide a one-way information flow where scientists contribute to the training of planning experts.

Our experience shows that planners regard the change of perspectives brought about by the game as extremely important and useful to learn about the process of urban sprawl in general, and also learn from potential alternative behavior in doing their professional business, making it the most important base for learning in the game. This is in accordance with typical experiences with games (Greenblat & Bredemeier, 1981), although playing a role in the game that is different to the professional roles can also pose problems of incertitude with the role (e.g. Backus 2005). Interestingly further, a certain type of behavior that is well-known by planners to be problematic is nevertheless often reproduced in the game. Such observations draw the attention to a socially constituted behavior that is extremely difficult to brake through.

When a role-play (without computer involvement) is used as a social simulation that is conceptually based on a formal model, the relations between role-play, reality and formal model are diverse. If we expect a similar impact from planning measures in the real-world as in the game, it has to be concluded that investments in the attractivity of a region in any form

are a strong incentive or dissensive for the moving actors both directly *and* indirectly. Under such circumstances the role for politics and planning in the urban sprawl process cannot be underestimated. This also implies that the assumptions behind the model – the interdependencies between actors and their contribution to locational attractiveness – are of a prominent value for urban planning processes. This conclusion was confirmed by the planning experts who played the game.

Such arguments, where properties of the formal model are validated by expert comments on the game, point at an important potential for using games jointly with models that was seldom explored so far to our knowledge and was not expected in the beginning. By playing a game with non-scientific experts, where the game is a medium to communicate a formal model, the teaching situation is shifted towards a dialogue where both sides learn from each other without the need to introduce the model itself in detail. If the game is designed as pure social simulation that is rooted in a formal model, new ways of communication are possible: through talking about the game the scientists can obtain feedback about the model without the need to explain mathematical matters to the audience – which may be difficult for those participants who are not used to mathematical and computational modeling methods. Thus, our approach provides an additional pivotal element for the transfer of game experience to real-world decision-making.

Acknowledgements

We want to thank especially our dear colleague and friend Gerhard Petschel-Held who was involved in both the development of the QuAM-Model and QuAG. Gerhard Petschel-Held cannot experience the application of the game and the results that we concluded from it anymore. We further want to thank our colleague Matthias Lüdeke for his substantial work in developing the computer model. Last but not least we thank our project partners from ICLEI, Holger Robrecht and Eric Sarvan who facilitated the workshops that offered a scene for playing QuAG with planners from all over Germany. Thanks as well to Holger Scheibig for his contribution in the development of the game as well as for his support during the playing sessions.

References

- Allen, P. M. (1997). *Cities and regions as selforganising systems: models of complexity*. Amsterdam: Gordon and Breach.
- Aubin, J.-P. (1991). *Viability theory*. Basel: Birkhäuser.
- Backus, G. & Amlin, J. (2005). Using gaming simulation to understand deregulation dynamics. *Simulation & Gaming: An International Journal*, 36(1), 45-57.
- Bredeweg, B. & Salles, P. (2003). Qualitative reasoning about population and community ecology. *Artificial Intelligence*, 24(4), 77-90.
- Cecchini, A. & Rizzi, P. (2001). Is urban gaming simulation useful? *Simulation & Gaming: An International Journal*, 32(4), 507-521.

- Cieslewicz (2002). The environmental impacts of sprawl. In Squires, G. D. (Ed.) *Urban sprawl - causes, consequences and policy response*. Washington D.C.: The Urban Institute Press.
- Coppard, L. C. & Goodman F. L. (Eds.) (1979). *Urban gaming/simulation - a handbook for educators and trainers*. Ann Arbor, Michigan: School of Education, the University of Michigan.
- Couclelis, H. (2005). Where has the future gone? Rethinking the role of integrated land-use models in spatial planning. *Environment & Planning A*, 37, 1353-1371.
- Lederman, L. C. (1992). Debriefing: towards a systematic assessment of theory and practice. *Simulation & Gaming: An International Journal*, 23(2), 145-160.
- Eisenack, K. & Petschel-Held, G. (2002). Graph theoretical analysis of qualitative models in sustainability science. In Agell, N. & Ortega, J. A. (Eds.) *Working papers of 16th workshop on qualitative reasoning* (pp. 53-60). Sevilla:Edición Digital@tres.
- Eisenack, K., Kropp, J. & Welsch, H. (2006). A qualitative dynamical modelling approach to capital accumulation in unregulated fisheries. *Journal of Economic Dynamics and Control*, DOI: 10.1016/j.jedc.2005.08.004.
- Eisenack, K. (2006). *Model ensembles for natural resource management: extensions of qualitative differential equations using graph theory and viability theory*. PhD Thesis. Berlin: Darwin, Free University Berlin. (<http://www.diss.fu-berlin.de/2006/326>).
- Forrester, J. W. (1968). *Principles of systems*. Cambridge: Wright-Allen-Press.
- Galster, G. (2001). Wrestling sprawl to the ground: defining and measuring an elusive concept. *Housing Policy Debate*, 12(4), 681-713.
- Gordon, I. R. & McCann, P. (2000). Industrial cluster: complexes, agglomeration and/or social networks? *Urban Studies*, 37(3), 513-532.
- Gosen, J. & Washbush J. (2004). A review of scholarship on assessing experiential learning effectiveness. *Simulation & Gaming: An International Journal*, 25(2), 270-293.
- Greenblat, C. S. & Duke, R. D. (1988). *Designing games and simulation - an illustrated handbook*. London: Sage publications.
- Greenblat, C. S. & Duke, R. D. (1981). *Principles and practices of gaming - simulation*. London: Sage publications.
- Greenblat, C. S. & Bredemeier M. E (1981). The educational effectiveness of simulation games - a synthesis of findings. *Simulation & Gaming: An Interdisciplinary Journal*, 12(3), 307-332.
- Herfert, G. (2002). Disurbanisation and Reurbanisation - polarisierte Raumentwicklung in der Ostdeutschen Schrumpflandschaft. *Raumforschung und Raumordnung*, 5-6, 334-344.
- Herfert, G. (2003). Zwischen Gentrification und Abwärtsspirale - sozialräumliche Differenzierung in Wohnquartieren Sächsischer Grossstadtreionen. *Raumforschung und Raumordnung*, 3, 170-184.
- Herfert, G. & Röhl, D. (2001). Leipzig - Region zwischen Boom und Leerstand. In Brake, K., Dangschat, J. S. & Herfert, G. (Eds.) *Suburbanisierung in Deutschland*. Opladen: Leske + Budrich.

- Jargowsky, P. A. (2002). Sprawl, concentration of poverty, and urban inequality. In Squires, G. D. (Ed.) *Urban sprawl - causes, consequences and policy responses*. Washington D.C.: The Urban Institute Press.
- Lüdeke, M. K. B., Meyer-Veden, D. & Petschel-Held, G. (2003). The qualitative attractivity-migration (QuAM) Model. Urbs Pandens working paper (September 2003), available at: <http://www.pik-potsdam.de/urbs/projekt/>.
- Lüdeke, M. K. B., Meyer-Veden, D. & Petschel-Held, G. (2004). Modellierung von Urban Sprawl am Beispiel von Leipzig. In UFZ-Diskussionspapiere (3/2004) *Schrumpfung und Urban Sprawl - Analytische und Planerische Problemstellungen*. Leipzig: UFZ.
- Lüdeke, M. K. B., Meyer-Veden, D. (2006). Qualitative attractivity models -a new approach to describe and predict urban development. Submitted to *Environment and Planning B*.
- Meyer-Veden, D., Lüdeke, M. K. B. (2006). The role of actors' preferences in residential sprawling and its application in a qualitative modelling approach inferring leverage points of the development. Submitted to *Environment and Planning B*.
- Petranek, C. (1994). A maturation in experiential learning: Principles of simulation and gaming. *Simulation & Gaming: An International Journal*, 25(3), 513-522.
- Petschel-Held, G. & Lüdeke, M. K. B. (2001): Integration of case studies by means of artificial intelligence. *Integrated Assessment*, 2(3), 123-138.
- Rhyne, R (1995). Field anomaly relaxation. *Futures*, 27(6), 657-674.
- Richardson, G. P. (1986). Problems with causal-loop diagrams. *Systems Dynamics Review*, 2, 158-170.
- Sietz, D., Untied, B., Walkenhorst, O., Lüdeke, M. K. B., Petschel-Held, G. & Schellnhuber, H.-J. (2006). Smallholder agriculture in Northeast Brazil: assessing heterogeneous human-environmental dynamics. *Regional Environmental Change*, DOI: 10.1007/s10113-005-0010-9.
- Squires, G. D. (2002). Urban Sprawl and the uneven development of metropolitan America. In Squires G. D. (Ed.) *Urban Sprawl - Causes, Consequences and Policy Response*. Washington D.C.: The Urban Institute Press.
- Sterman, J. D. (2000). *Business dynamics, systems thinking and modeling for a complex World*. New York: Irwin/McGraw Hill.
- Tobler, W. (1979). Cellular geography. In Gale, S. & Olson, G. (Eds.) *Philosophy in Geography* (pp. 379-386). Dordrecht: Reidel.
- Torres, M. & Macedo., J. (2000). Learning sustainable development with a new simulation game. *Simulation & Gaming: An International Journal*, 31(1), 119-126.
- Wiest, K. (2001). Die Stabilität von Wohngebieten in schrumpfenden Städten Sachsens: Eine Analyse charakteristischer Problemkonstellationen. *Europa Regional*, 2001, 192-203.
- Zadeh, L. A. (1965). Fuzzy sets. *Information and Control*, 8, 338-353.
- Zell, A. (1994). *Simulation Neuronaler Netze*. New York: Addison Wesley.